

**RELAÇÃO DO AÇO**

AÇO	N	DIAM (mm)	QUANT	C.UNIT (cm)	C.TOTAL (cm)
CA60	1	5.0	16	65	1040
	2	5.0	8	45	360
	3	5.0	38	75	2850
	4	5.0	22	55	1210
	5	5.0	20	75	1500
	6	5.0	12	60	720
	7	5.0	10	26	260
	8	5.0	8	85	680
	9	5.0	4	60	240
CA50	10	8.0	71	129	9159
	11	8.0	42	144	6048
	12	8.0	20	139	2760
	13	8.0	12	154	1848
	14	8.0	12	114	1368
	15	8.0	10	129	1290
	16	8.0	12	124	1488
	17	8.0	13	159	2067
	18	10.0	16	197	3152
	19	12.5	34	205	6970

**RESUMO DO AÇO**

AÇO	DIAM (mm)	C.TOTAL (m)	PESO + 10% (kg)
CA50	8.0	260.5	113.1
	10.0	31.5	21.4
	12.5	69.7	73.9
CA60	5.0	88.6	15
<b>PESO TOTAL (kg)</b>			<b>208.3</b>
CA50			15
CA60			15

Volume de concreto (C-30) = 0.57 m<sup>3</sup>  
Volume de concreto (C-25) = 3.67 m<sup>3</sup>  
Area de forma = 17.80 m<sup>2</sup>

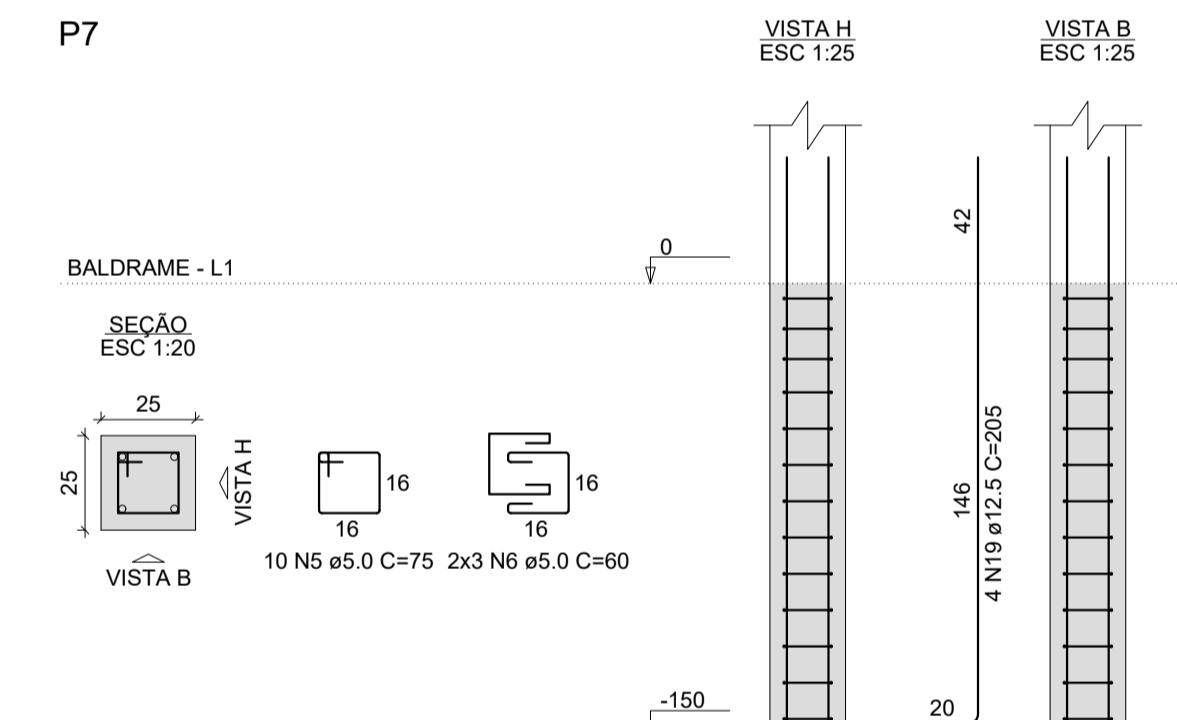
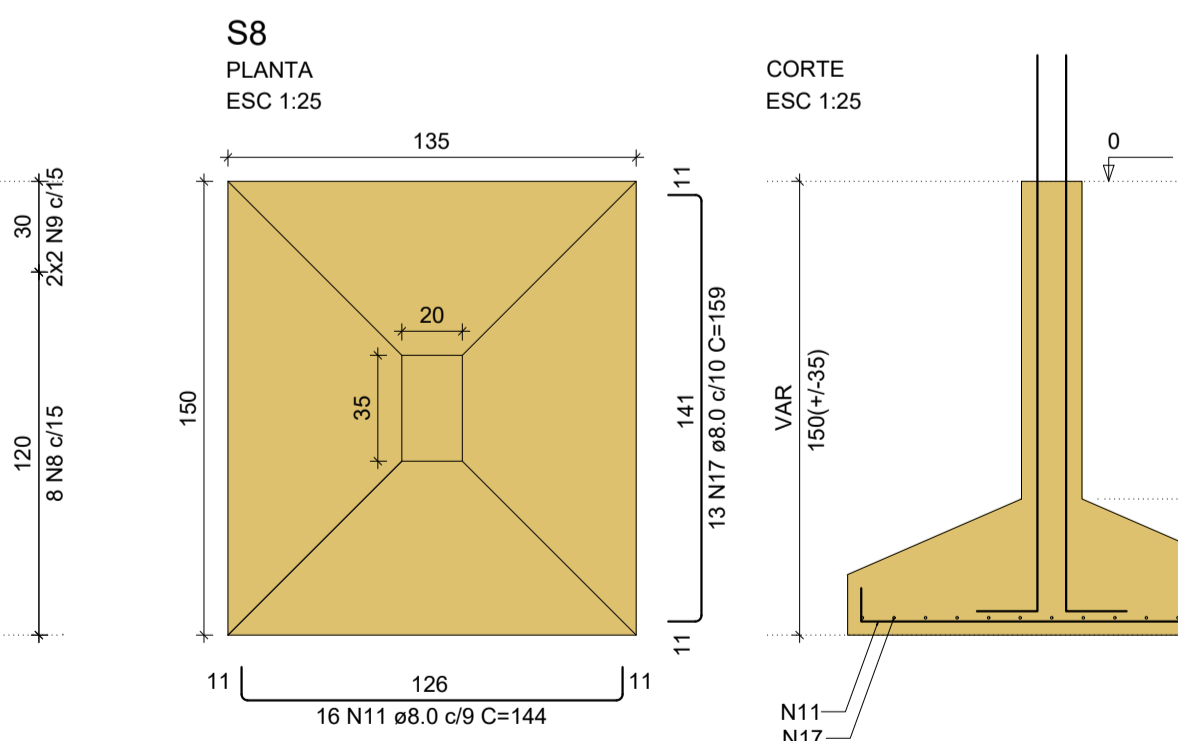
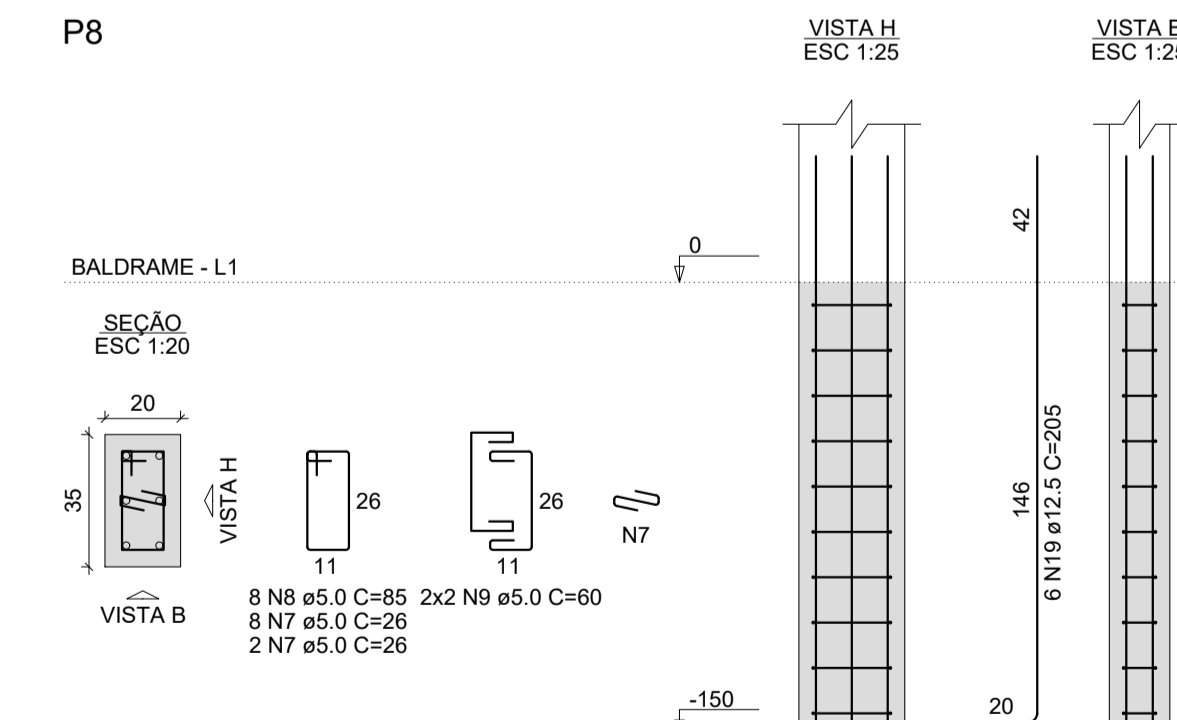
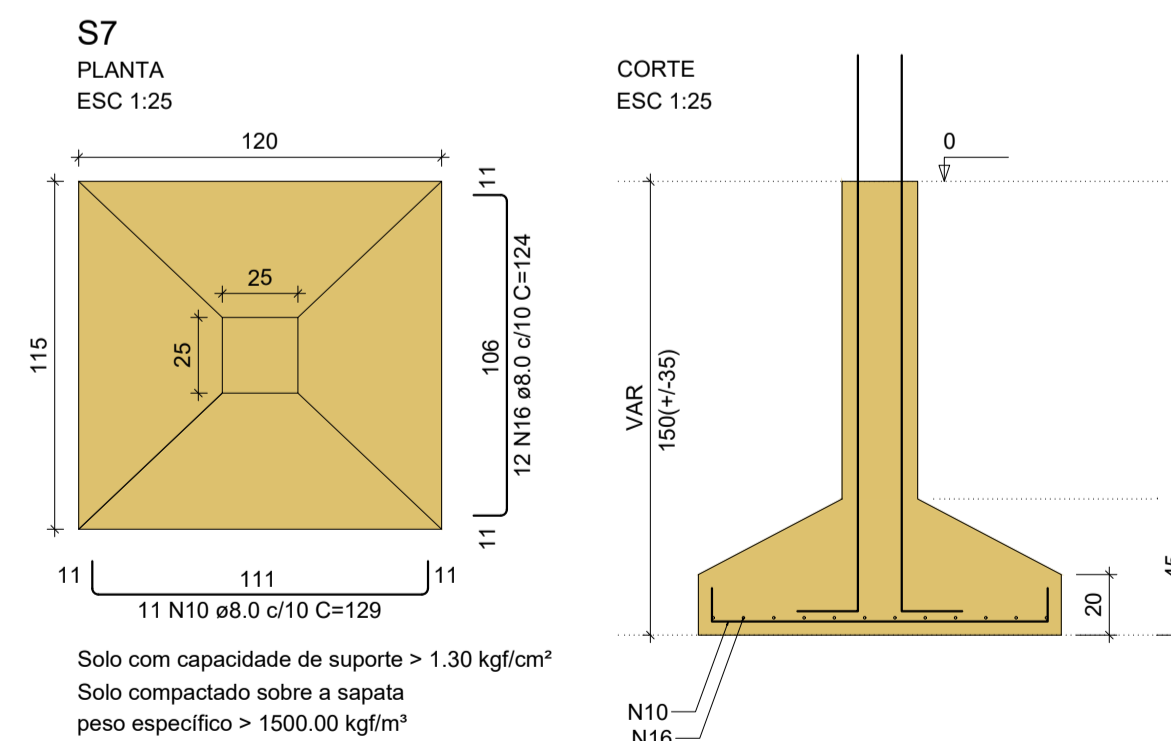
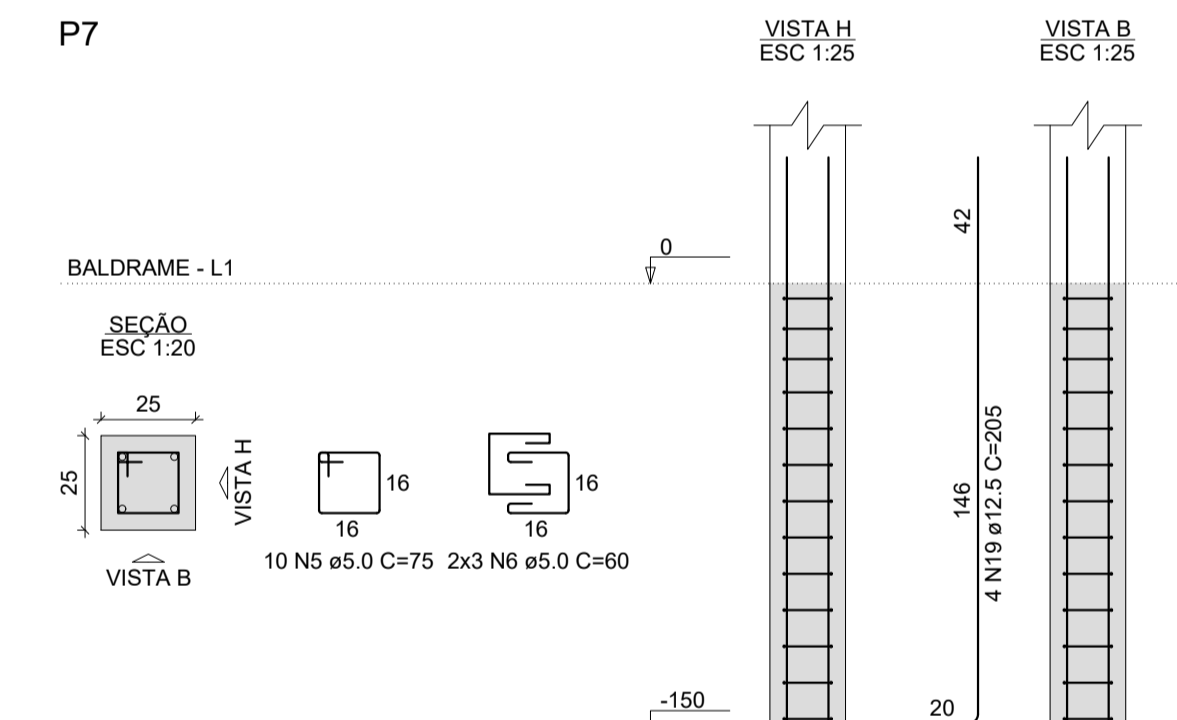
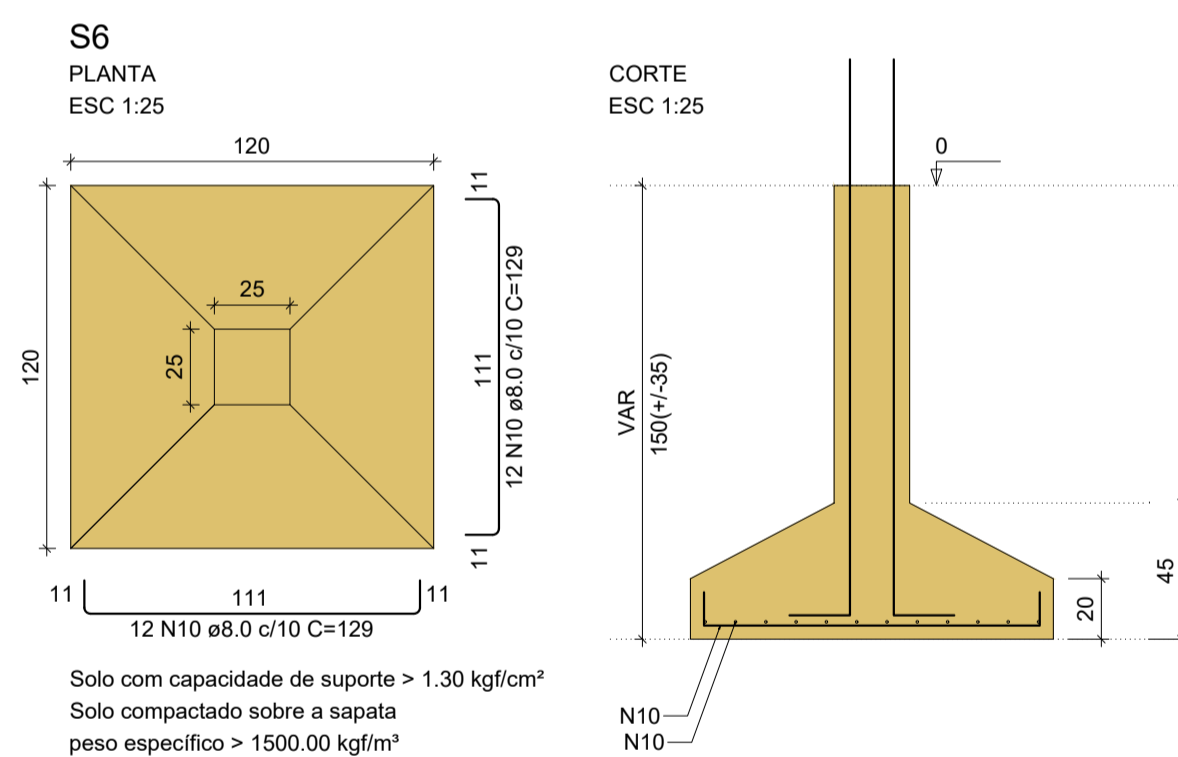
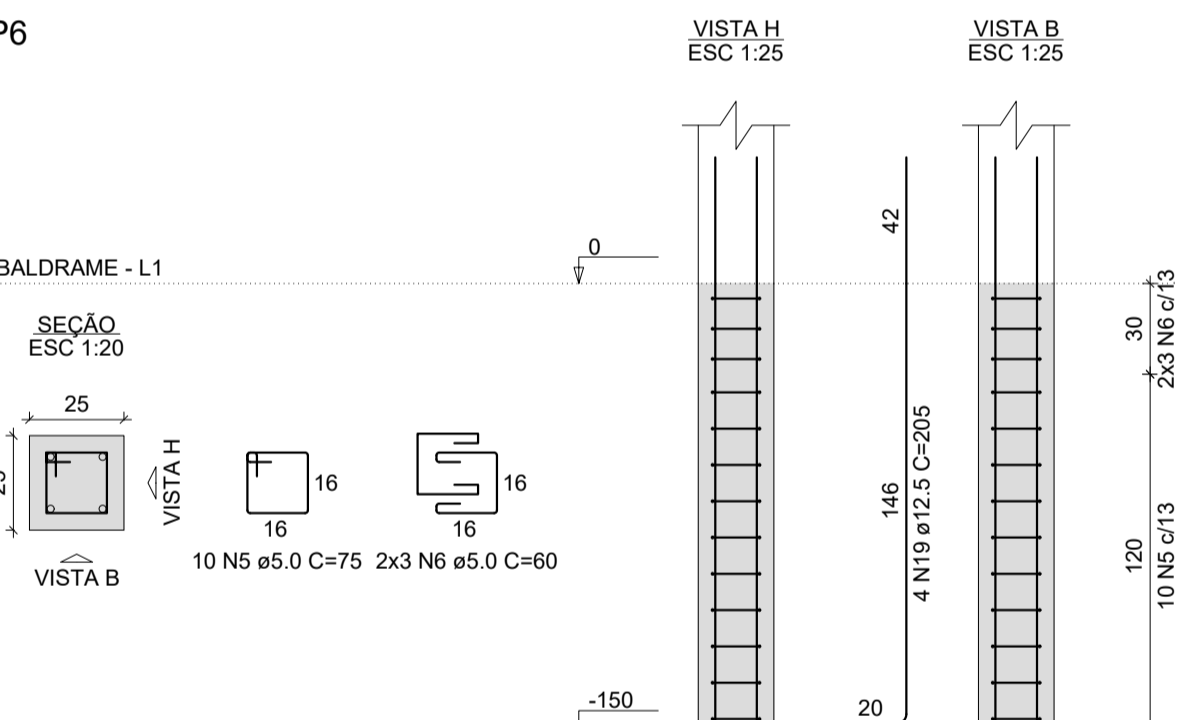
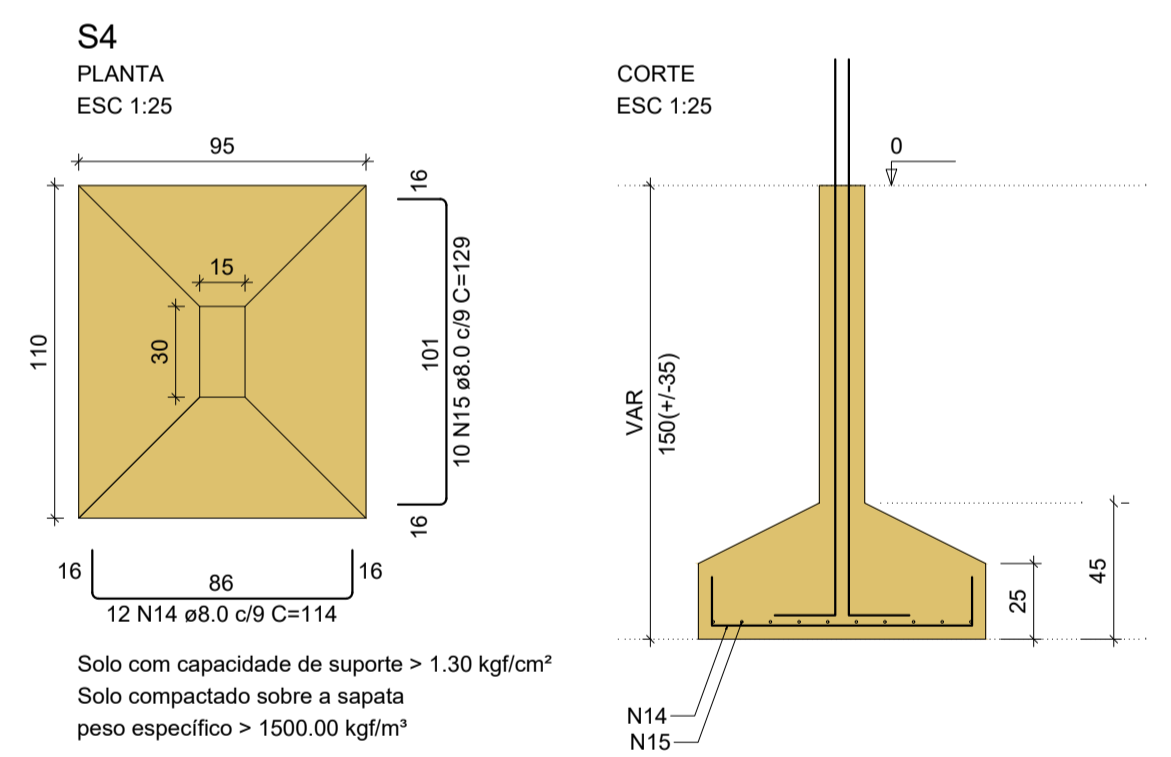

**GeoNorte** Projetos e Topografia

**GEONORTE PROJETOS LTDA.**  
Av. Brasil, 79, sala 09, Centro - Xanxerê (SC) - 89820-000  
www.geonorte.net.br / contato@geonorte.net.br  
Telefone: (49) 3433-8176

**PROJETO ESTRUTURAL EDIFICAÇÃO 01:**  
**REFORMA E AMPLIAÇÃO DO CENTRO COMUNITÁRIO DO BAIRRO SÃO CRISTÓVÃO**

LOCALIDADES:  
MUNICÍPIO: FAXINAL DOS GUEDES  
DATA: 10/2023

ESTADO UF: SC  
ESCALA: indicada

Conteúdo:  
DETALHAMENTO DE SAPATAS E ARRANQUES 1/2

Folha:  
**03/11**

Prop.:  
PREFEITURA MUNICIPAL DE FAXINAL DOS GUEDES  
CNPJ:

Resp. Téc.:  
CARLO ANTUNES DOS SANTOS  
ENGENHEIRO CIVIL  
CREA-SC 123.879-1