

P1

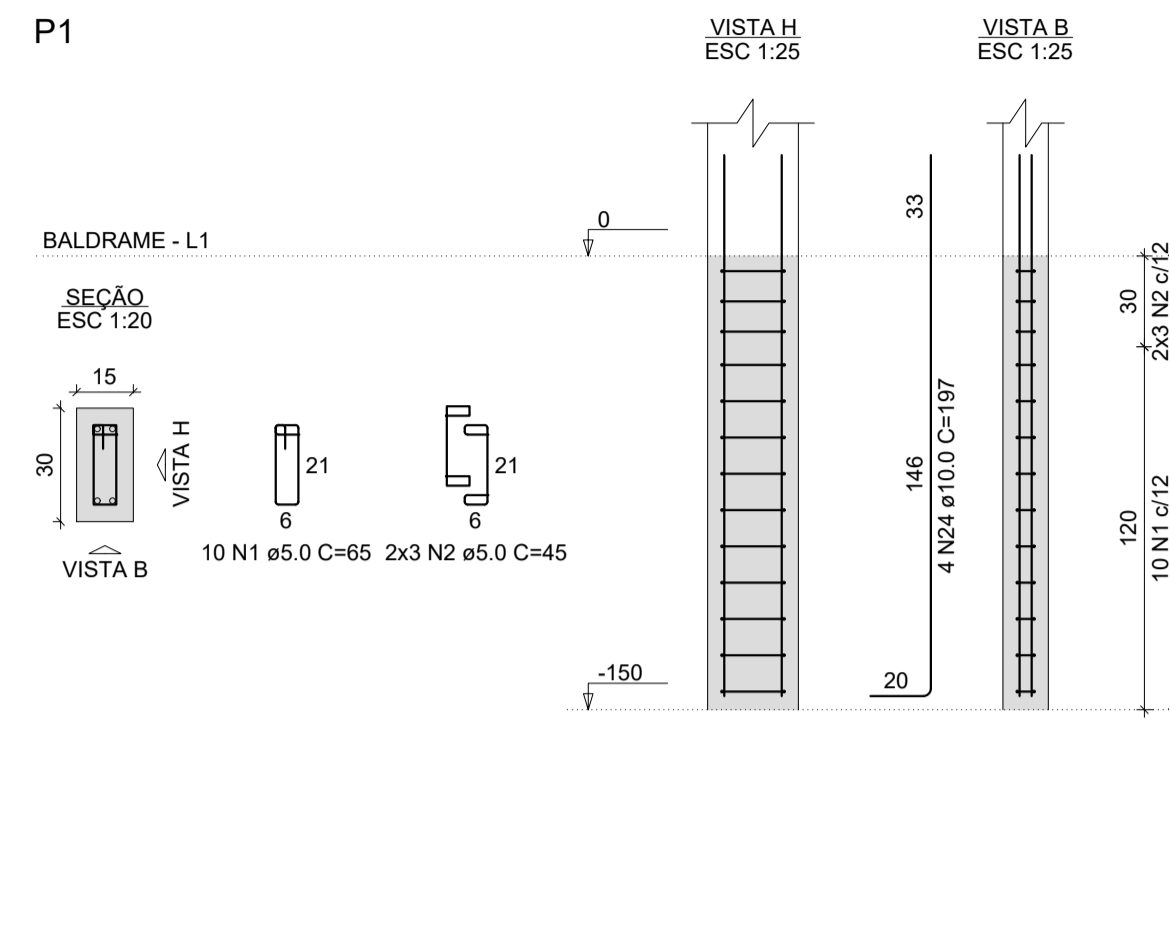

S1
PLANTA
ESC 1:25

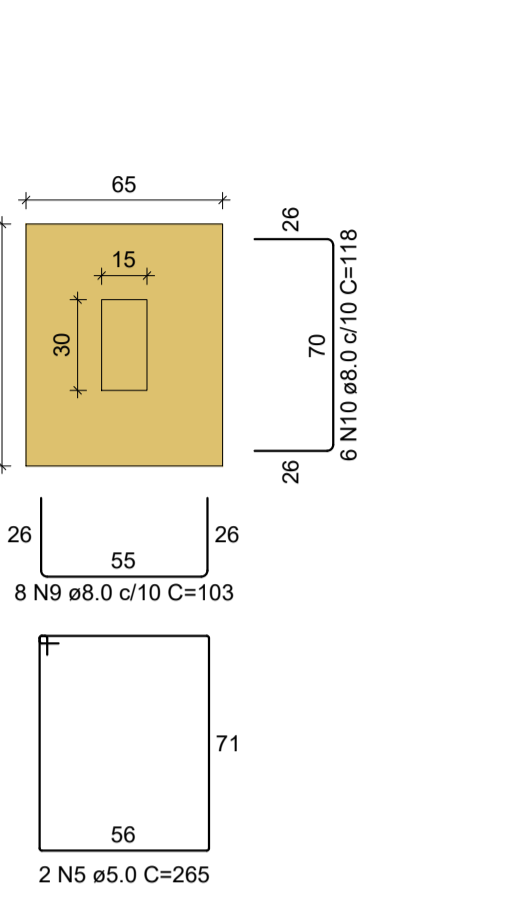

CORTE
ESC 1:25

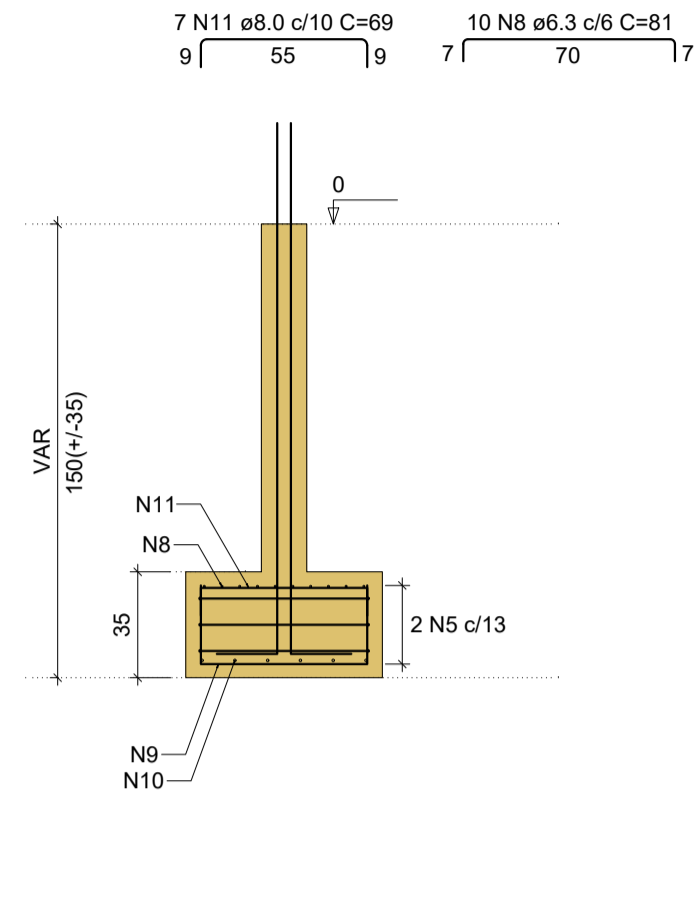

P2=P11

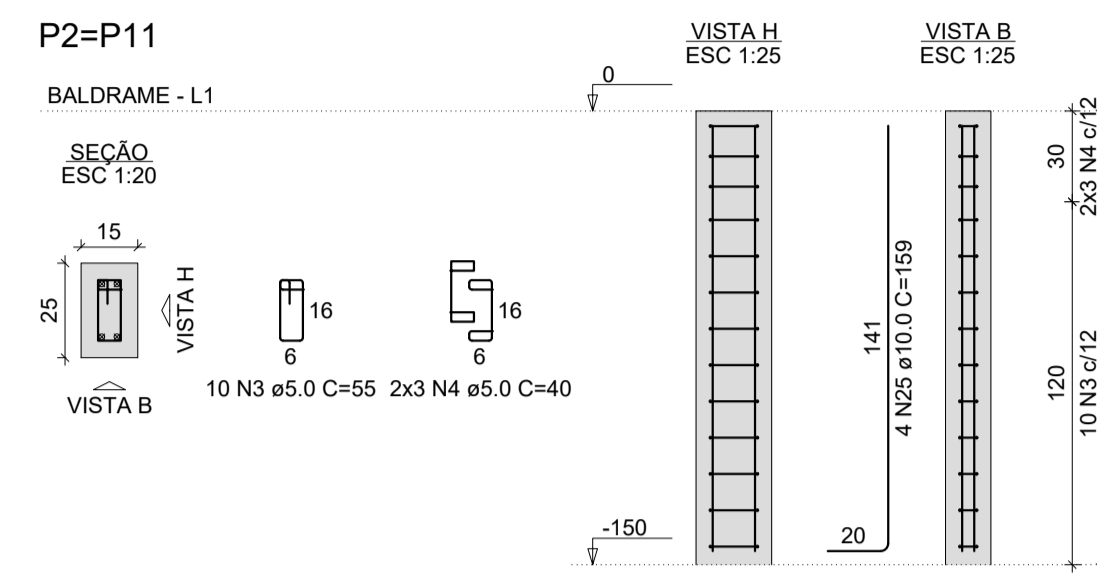

P7

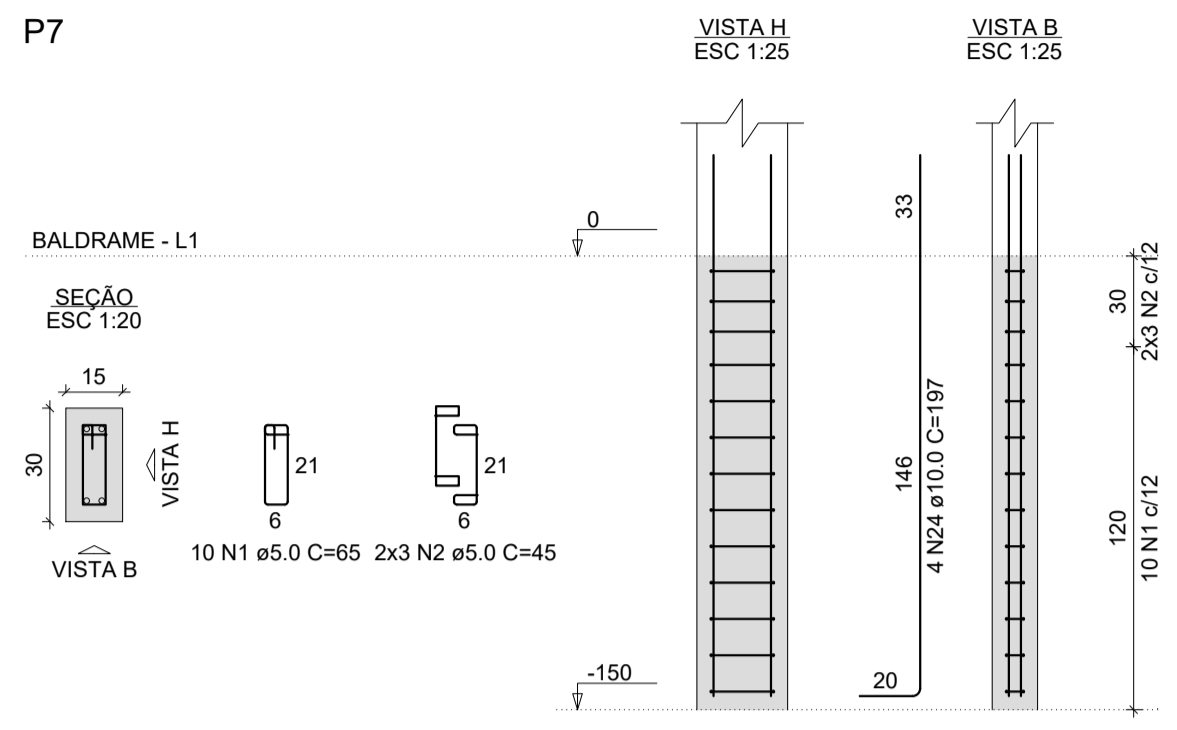

RELAÇÃO DO AÇO

AÇO	N	DIAM (mm)	QUANT	C.UNIT (cm)	C.TOTAL (cm)
CA60	1	5.0	40	65	2600
	2	5.0	24	45	1080
	3	5.0	40	55	2200
	4	5.0	24	40	960
	5	5.0	2	265	530
	6	5.0	2	355	710
	7	5.0	2	385	770
CA50	8	6.3	10	81	810
	9	8.0	8	103	824
	10	8.0	6	118	708
	11	8.0	7	69	483
	12	8.0	10	123	1230
	13	8.0	8	143	1144
	14	8.0	10	89	890
	15	8.0	8	109	872
	16	8.0	16	89	1424
	17	8.0	12	99	1188
	18	8.0	11	133	1463
	19	8.0	9	148	1332
	20	8.0	10	99	990
	21	8.0	9	114	1026
	22	8.0	21	84	1764
	23	8.0	18	94	1692
	24	10.0	16	197	3152
	25	10.0	16	159	2544

RESUMO DO AÇO

AÇO	DIAM (mm)	C.TOTAL (m)	PESO + 10% (kg)
CA50	6.3	8.1	2.2
	8.0	170.3	73.9
	10.0	57	38.6
CA60	5.0	88.5	15

PESO TOTAL (kg)
CA50 114.7
CA60 15

Volume de concreto (C-30) = 0.38 m³
Volume de concreto (C-25) = 1.75 m³
Área de forma = 14.88 m²

S2=S7=S11

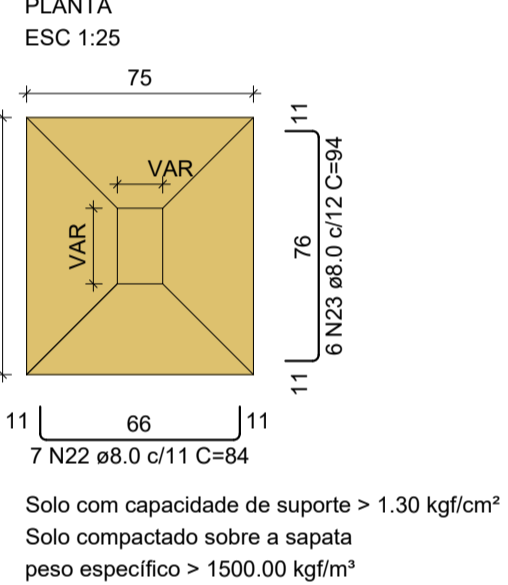

CORTE
ESC 1:25

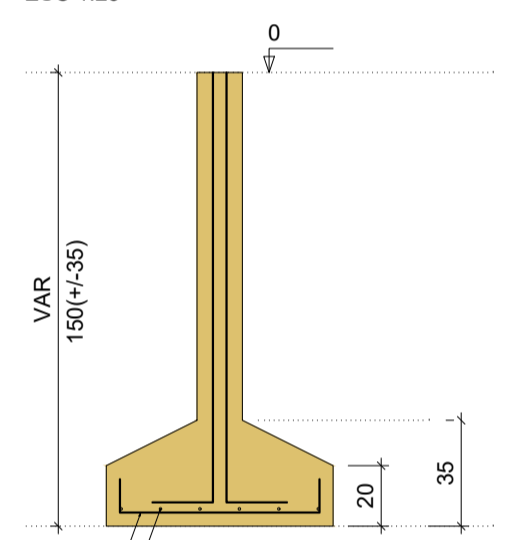

P4

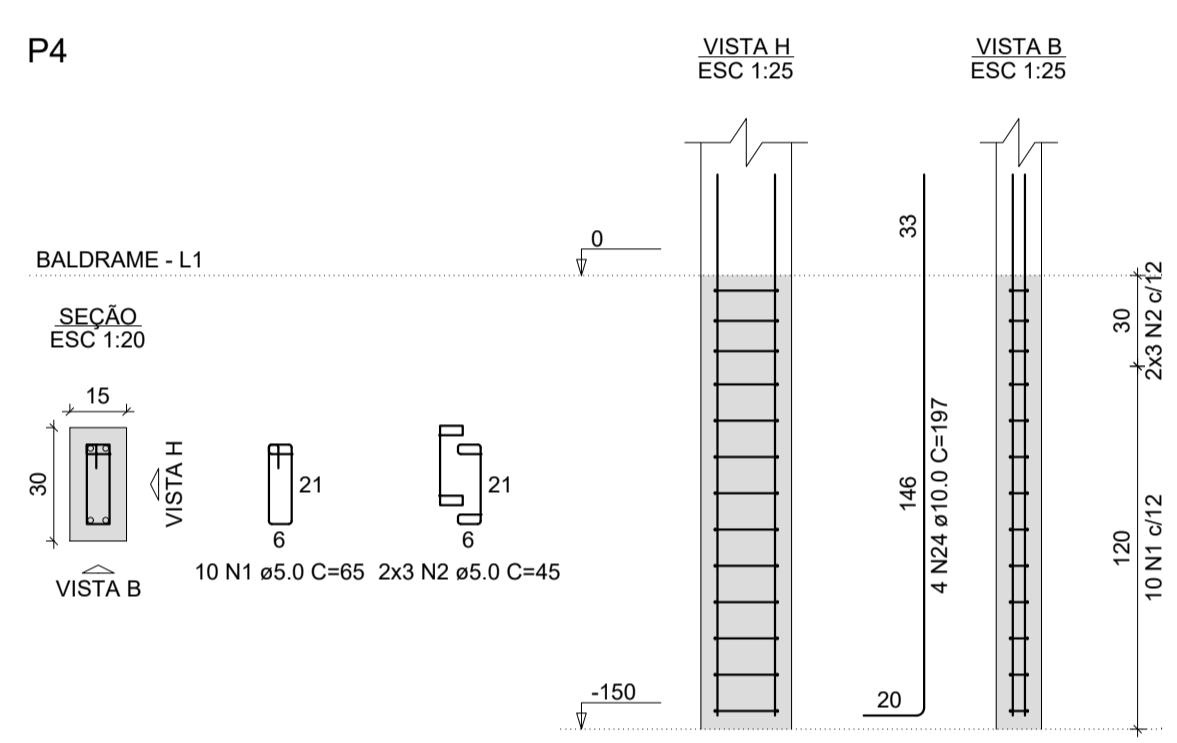

S4
PLANTA
ESC 1:25

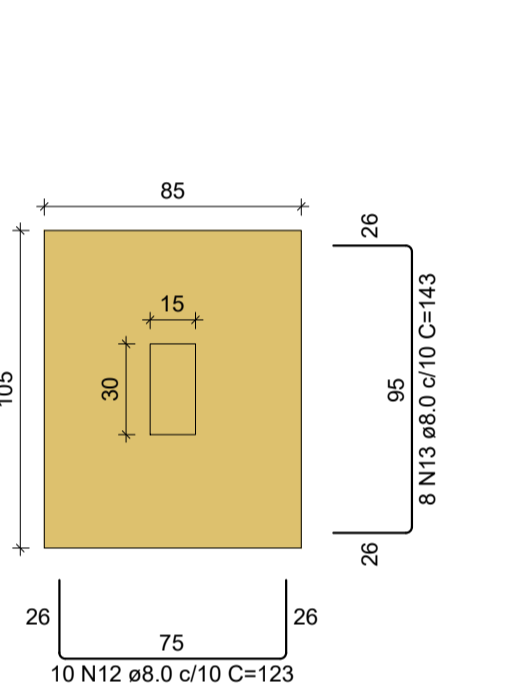

CORTE
ESC 1:25

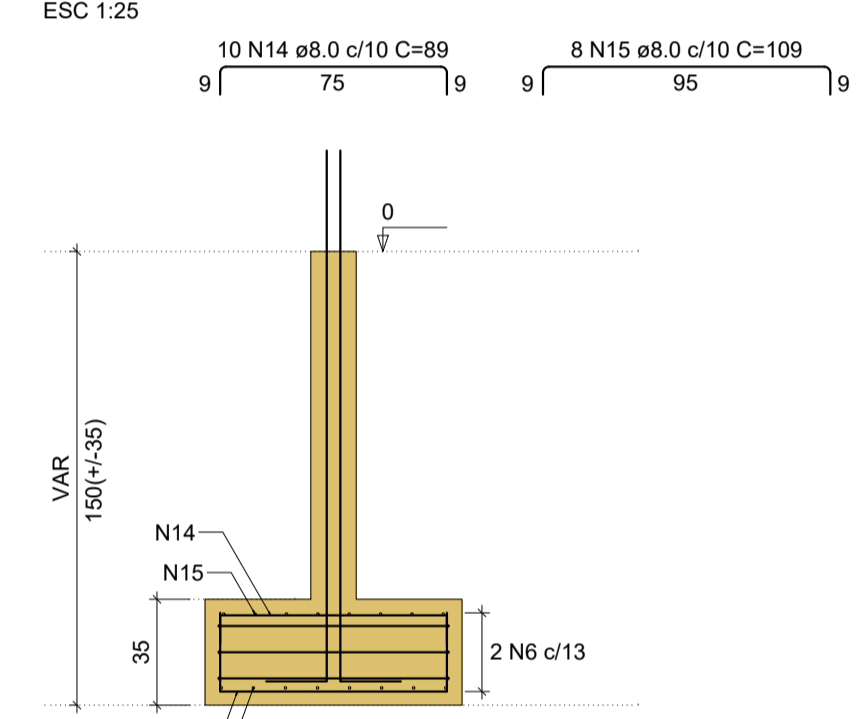

P5=P8

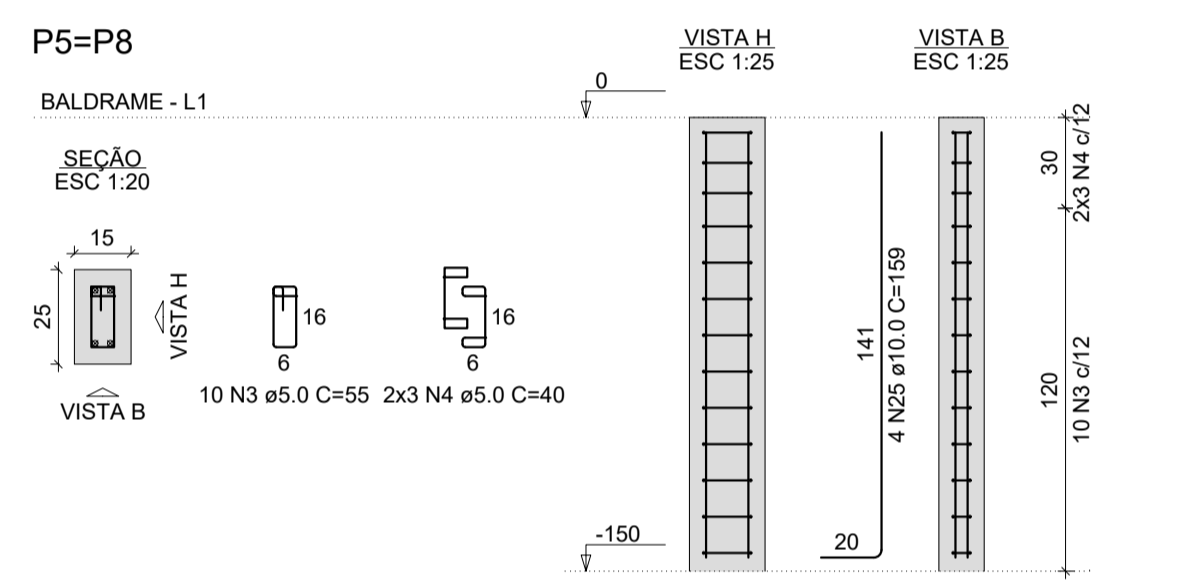

S5=S8

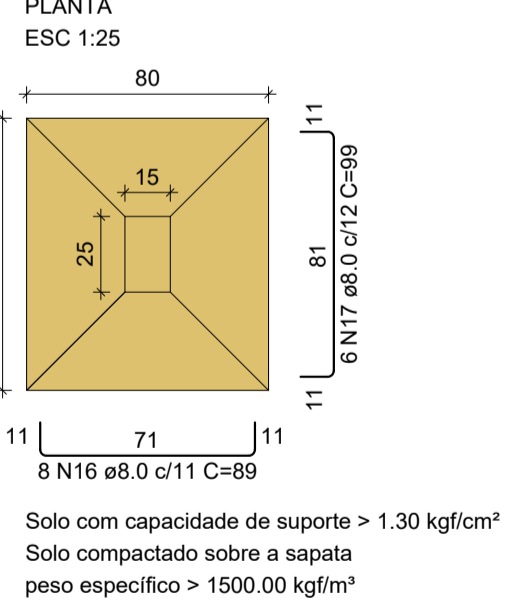

CORTE
ESC 1:25

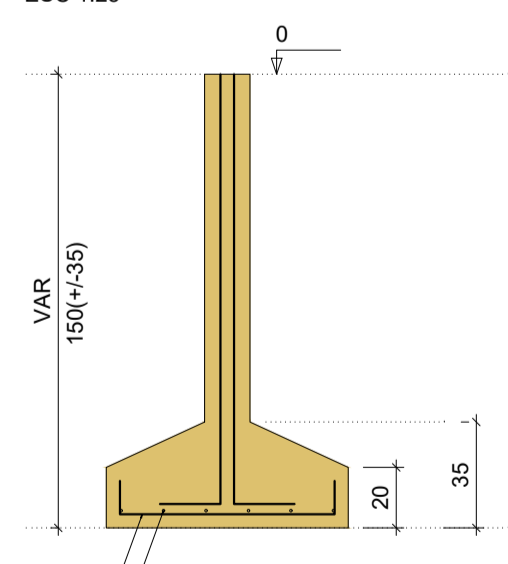

P10

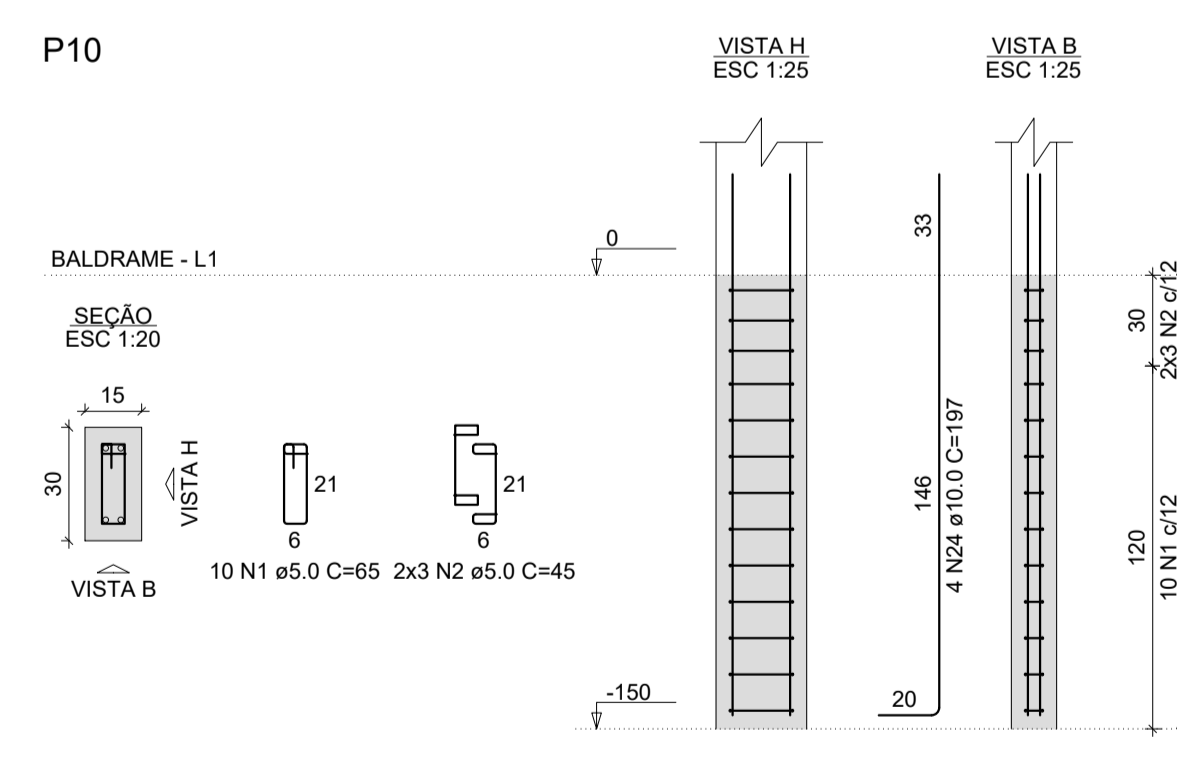

S10
PLANTA
ESC 1:25

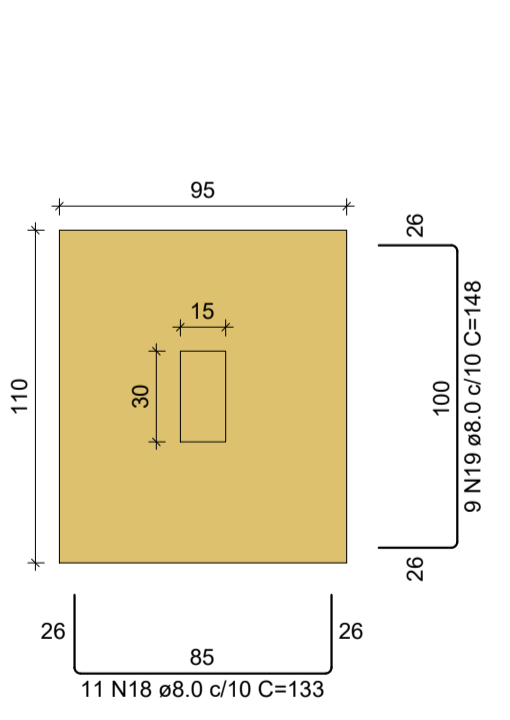

CORTE
ESC 1:25

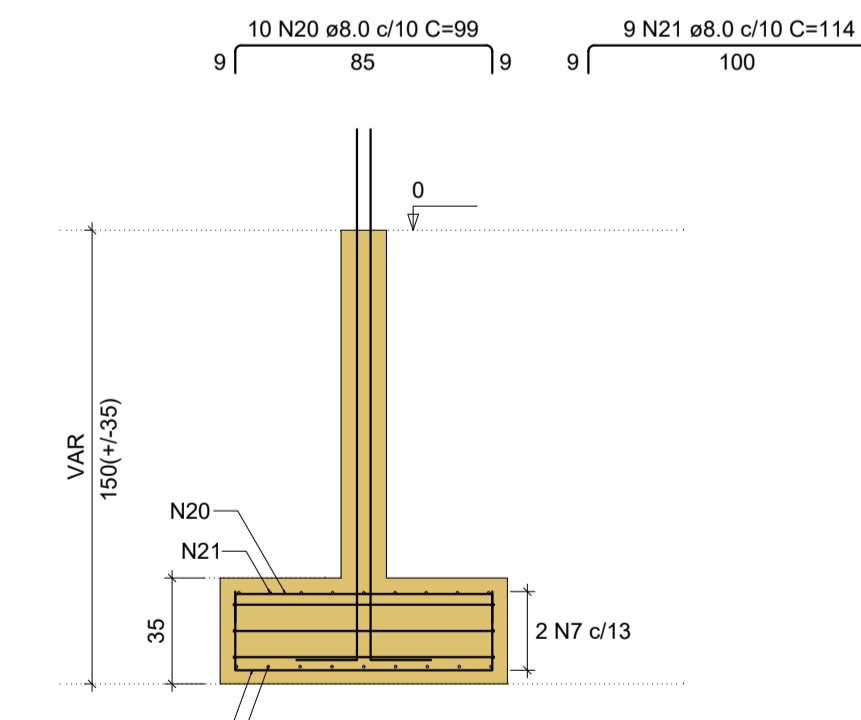

Solo com capacidade de suporte > 1.30 kgf/cm²
Solo compactado sobre a sapata
peso específico > 1500.00 kgf/m³

GeoNorte Projetos e Topografia
GEONORTE PROJETOS LTDA.
 Av. Brasil, 79, sala 09, Centro - Xanxerê (SC) - 89820-000
 www.geonorte.net.br / contato@geonorte.net.br
 Telefone: (49) 3433-8176

PROJETO ESTRUTURAL EDIFICAÇÃO 02:
REFORMA E AMPLIAÇÃO DO CENTRO COMUNITÁRIO DO BAIRRO SÃO CRISTÓVÃO

LOCALIDADES:
 MUNICÍPIO: FAXINAL DOS GUEDES ESTADO UF: SC
 DATA: 10/2023 ESCALA: indicada

Conteúdo:
 DETALHAMENTO SAPATAS E ARRANQUES

Folha:
03/04

Prop.:
 PREFEITURA MUNICIPAL DE FAXINAL DOS GUEDES
 CNPJ:

Resp. Téc.:
 CARLO ANTUNES DOS SANTOS
 ENGENHEIRO CIVIL
 CREA-SC 123.879-1