

S1=S28
PLANTA
ESC 1:25

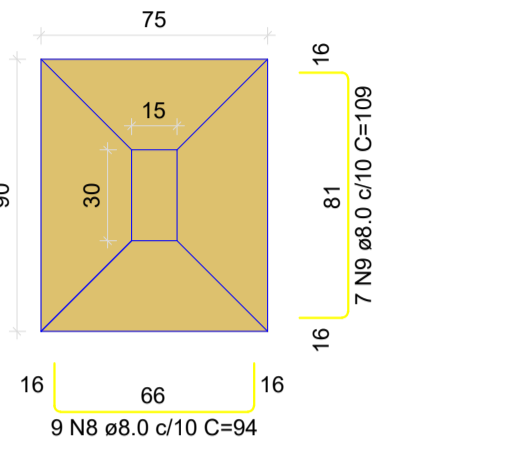

Solo com capacidade de suporte > 1.50 kgf/cm²
Solo compactado sobre a sapata
peso específico > 1600.00 kg/m³

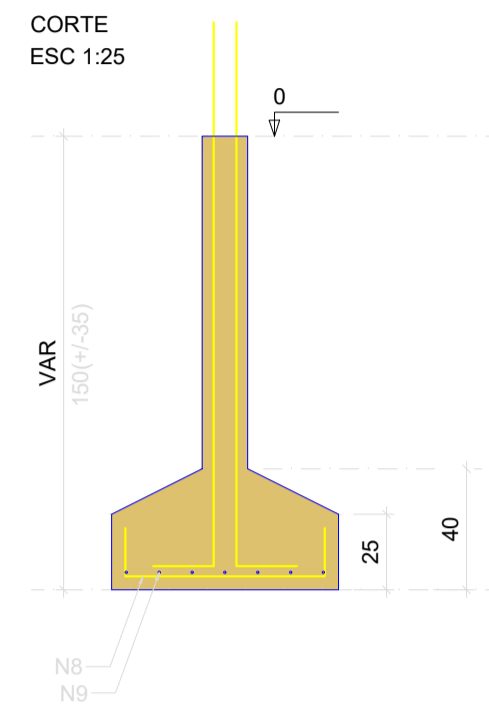

P1

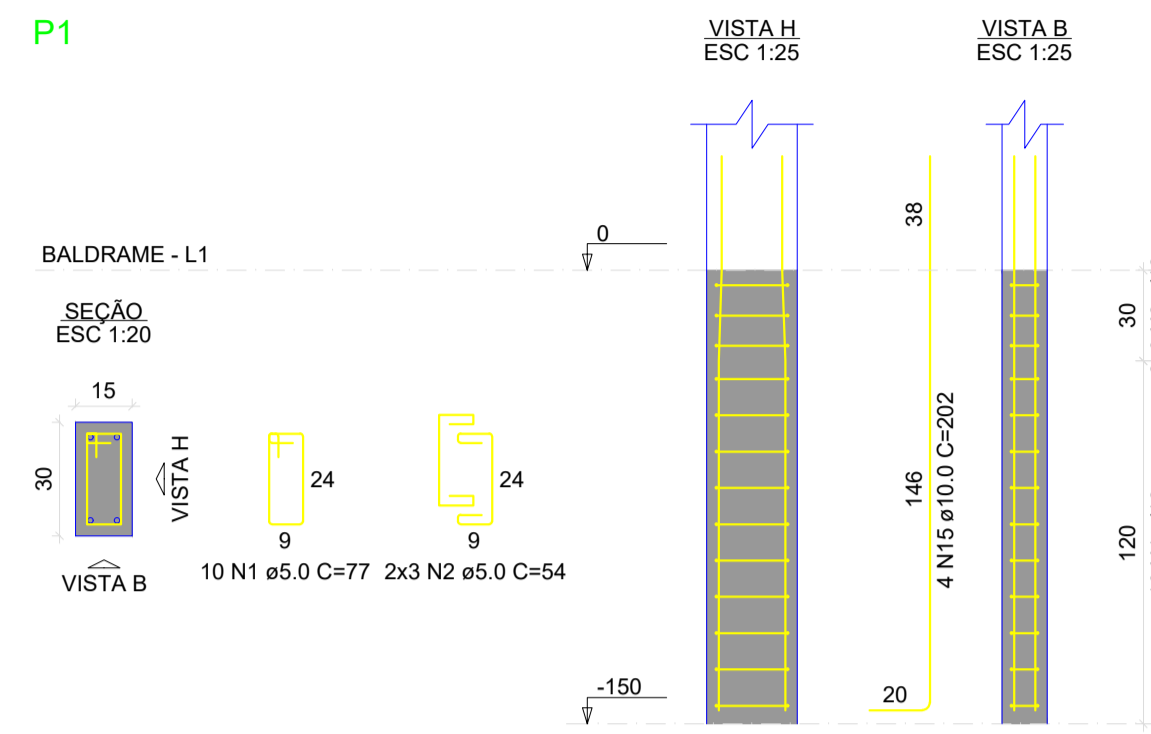

P28

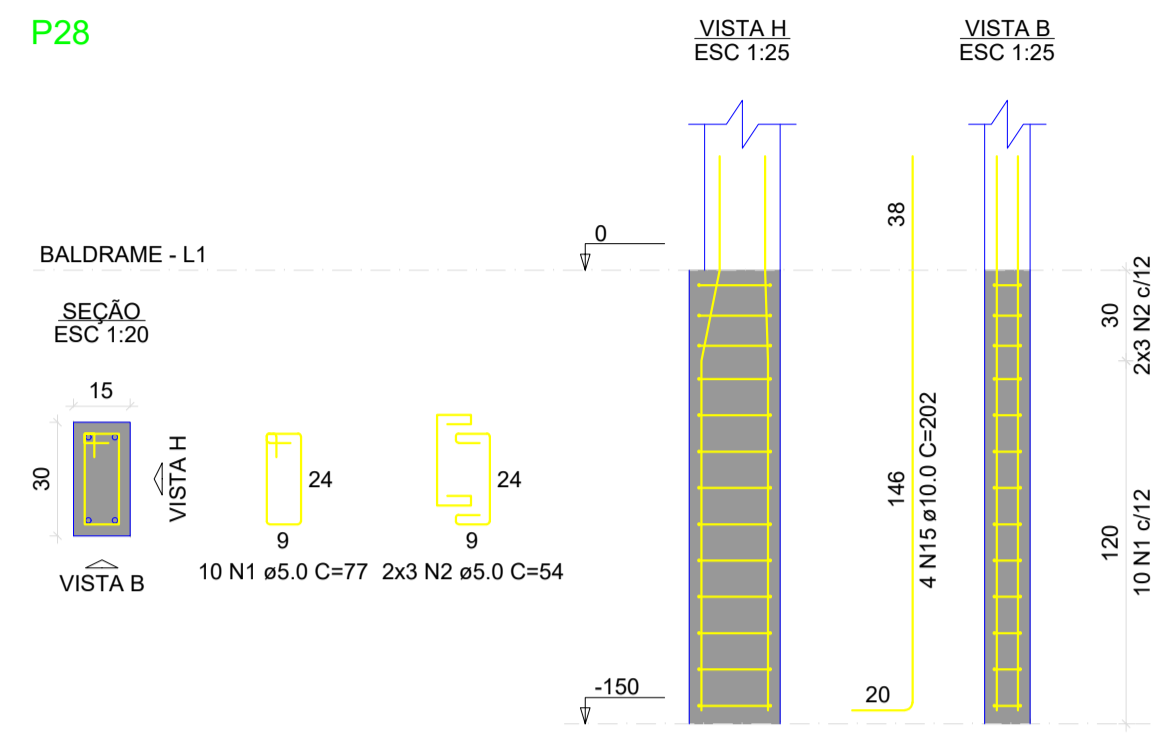

S2=S8=S16=S37=S38
PLANTA
ESC 1:25

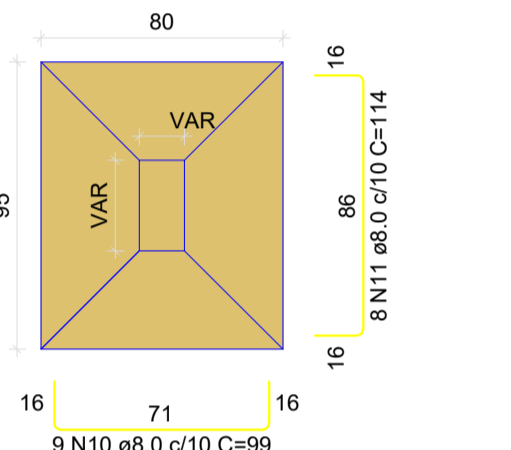

Solo com capacidade de suporte > 1.50 kgf/cm²
Solo compactado sobre a sapata
peso específico > 1600.00 kg/m³

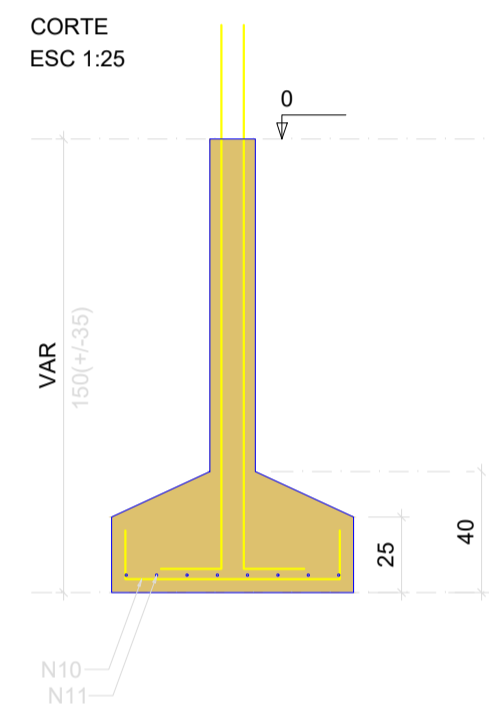

P8=P16=P37

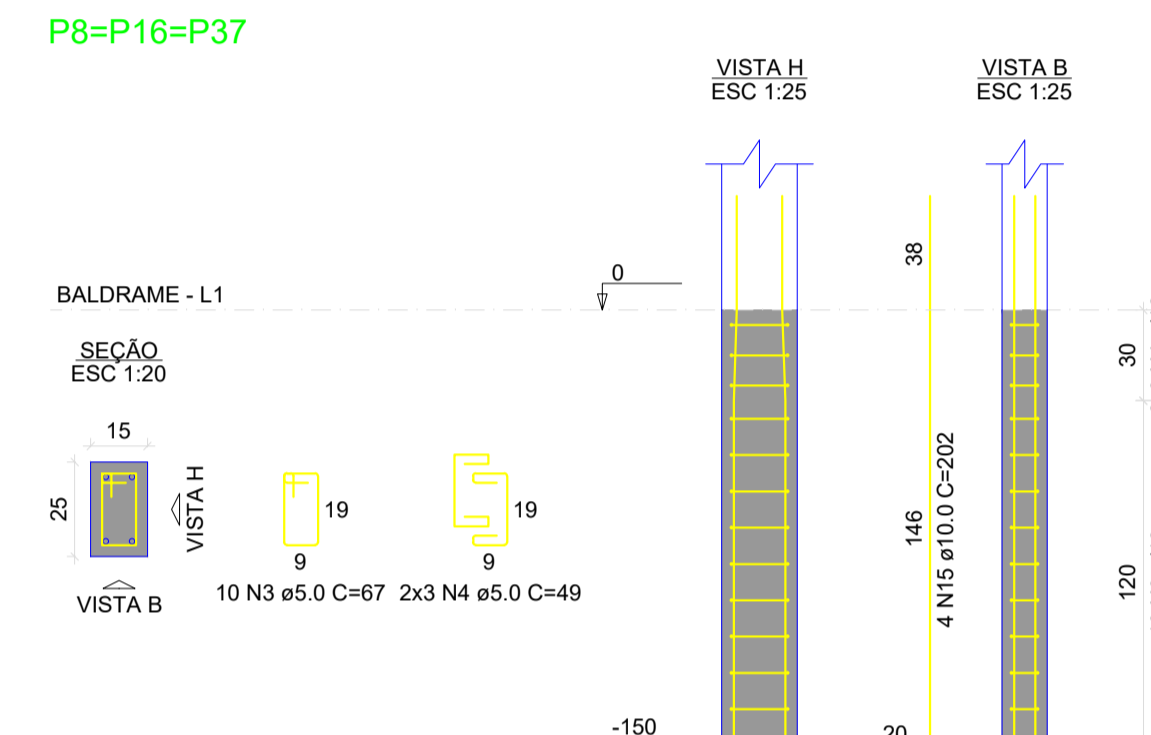

P2

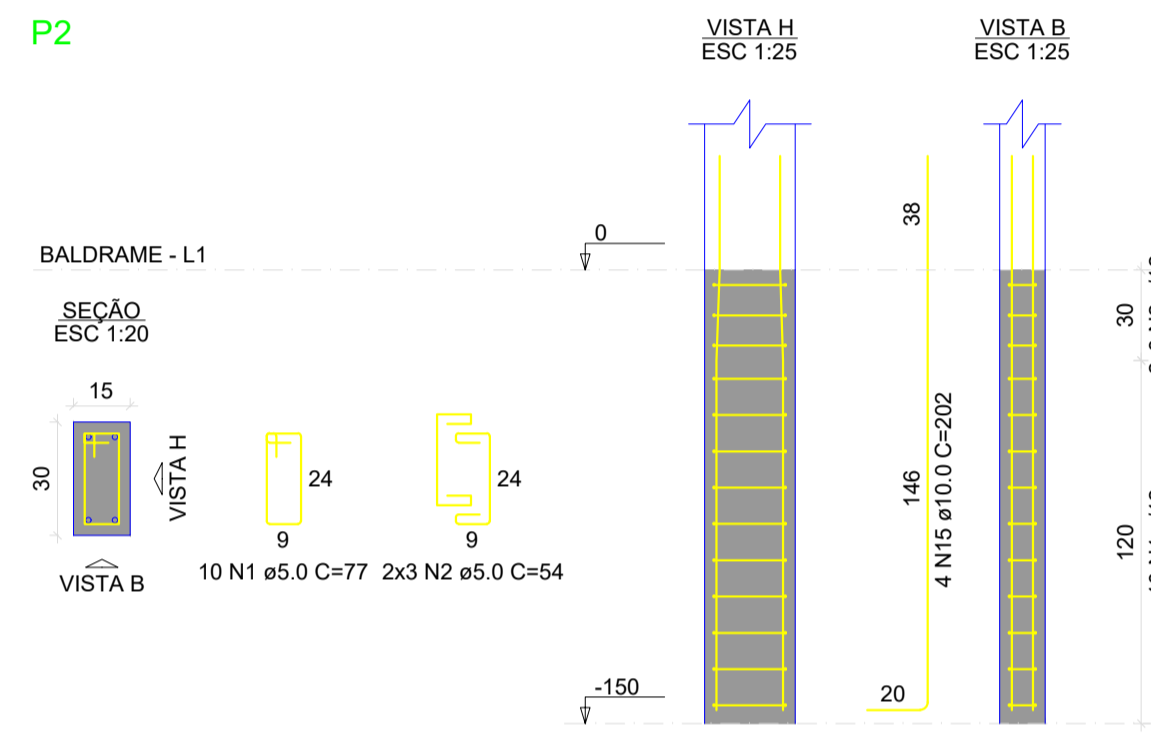

P38

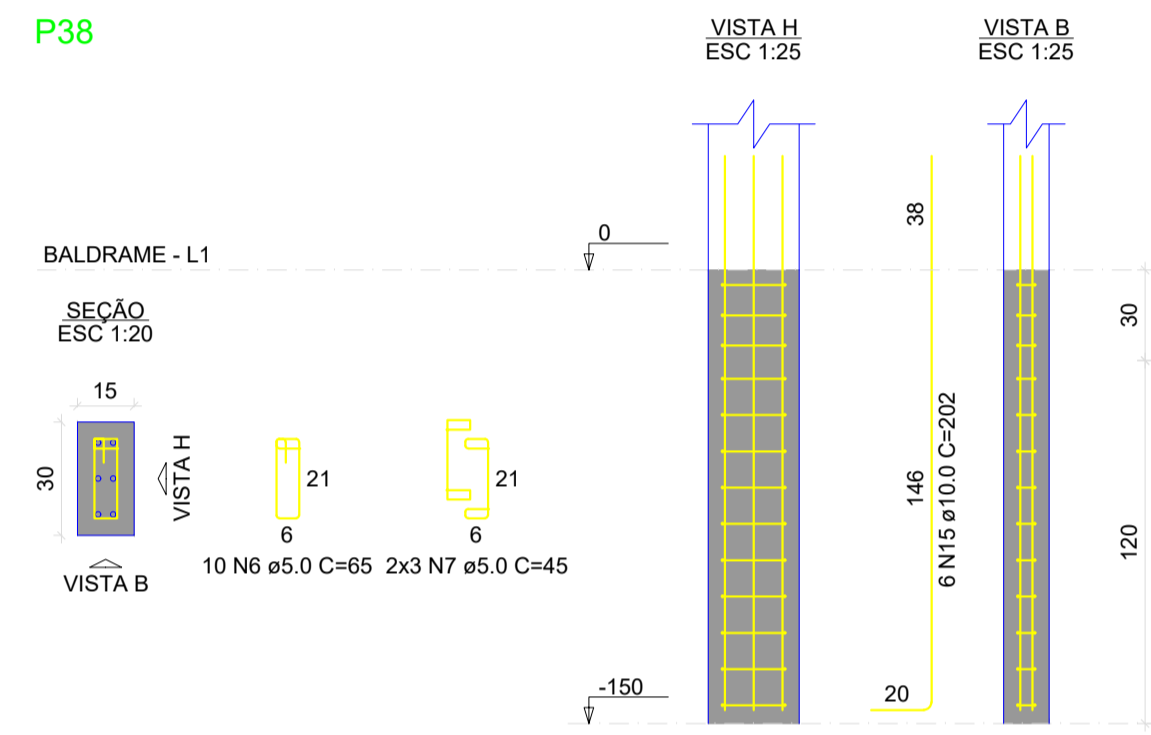

S3=S5=S6=S12=S13=S14=S19=S20=S21=S25
=S30=S33=S34
PLANTA
ESC 1:25

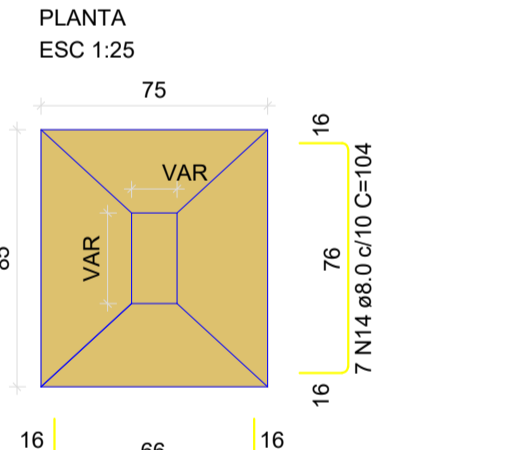

Solo com capacidade de suporte > 1.50 kgf/cm²
Solo compactado sobre a sapata
peso específico > 1600.00 kg/m³

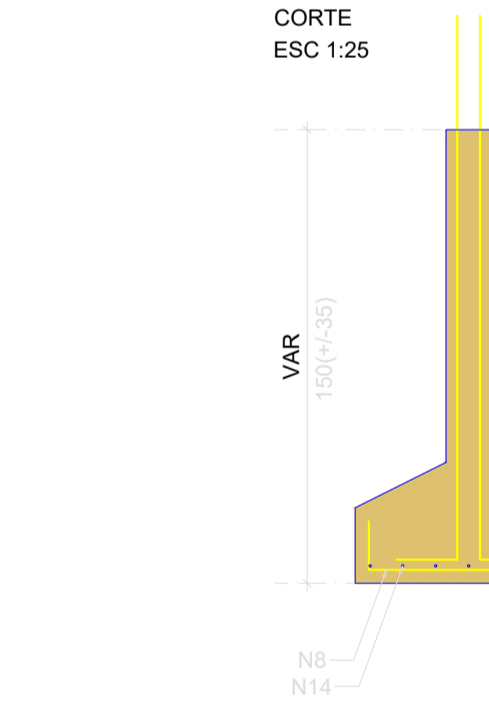

P14

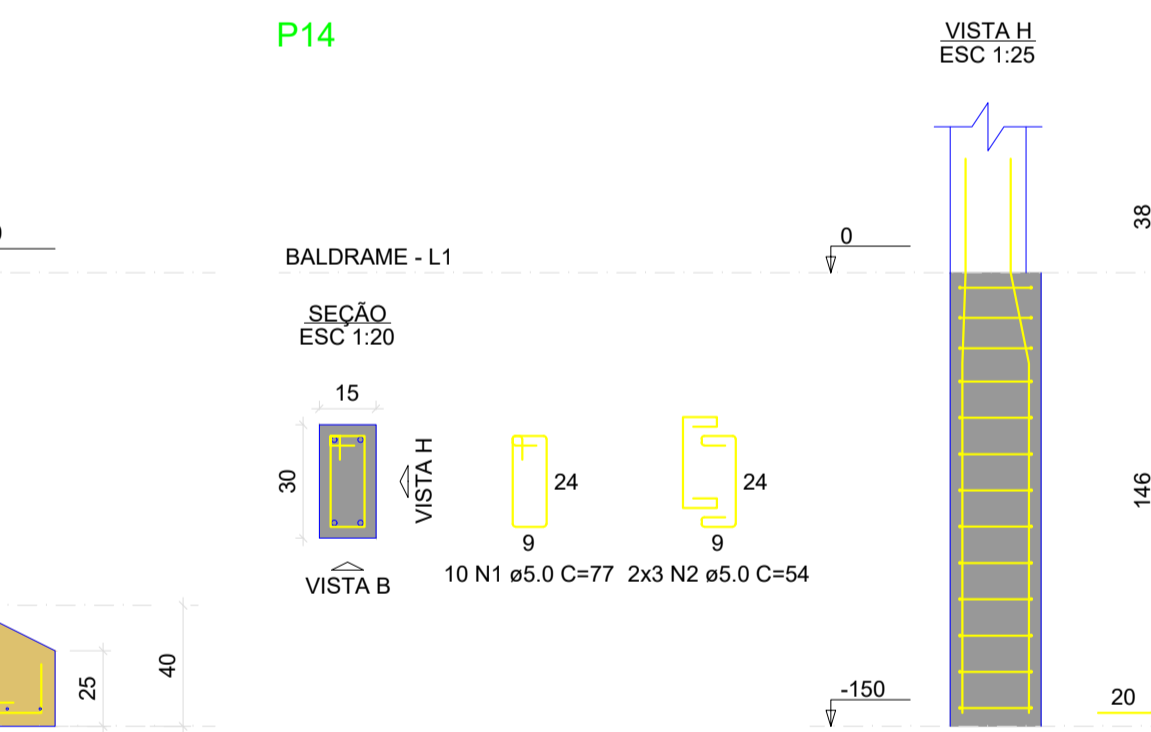

P2

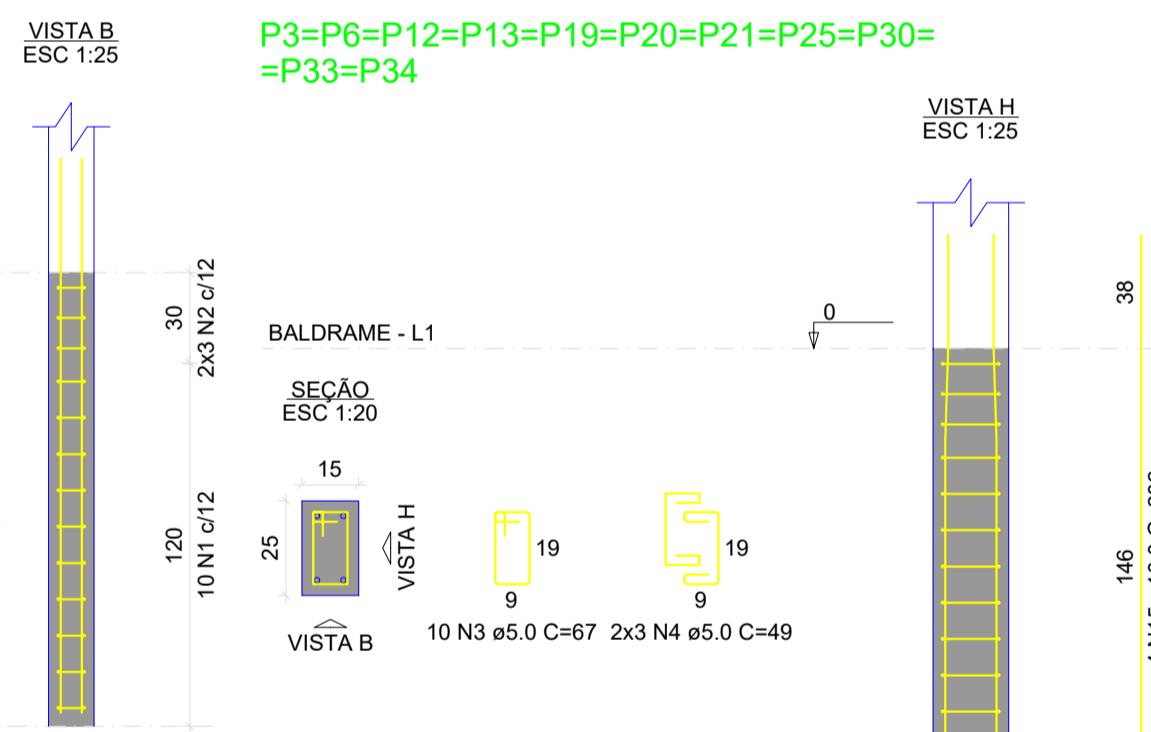

P3=P6=P12=P13=P19=P20=P21=P25=P30=
=P33=P34

P5

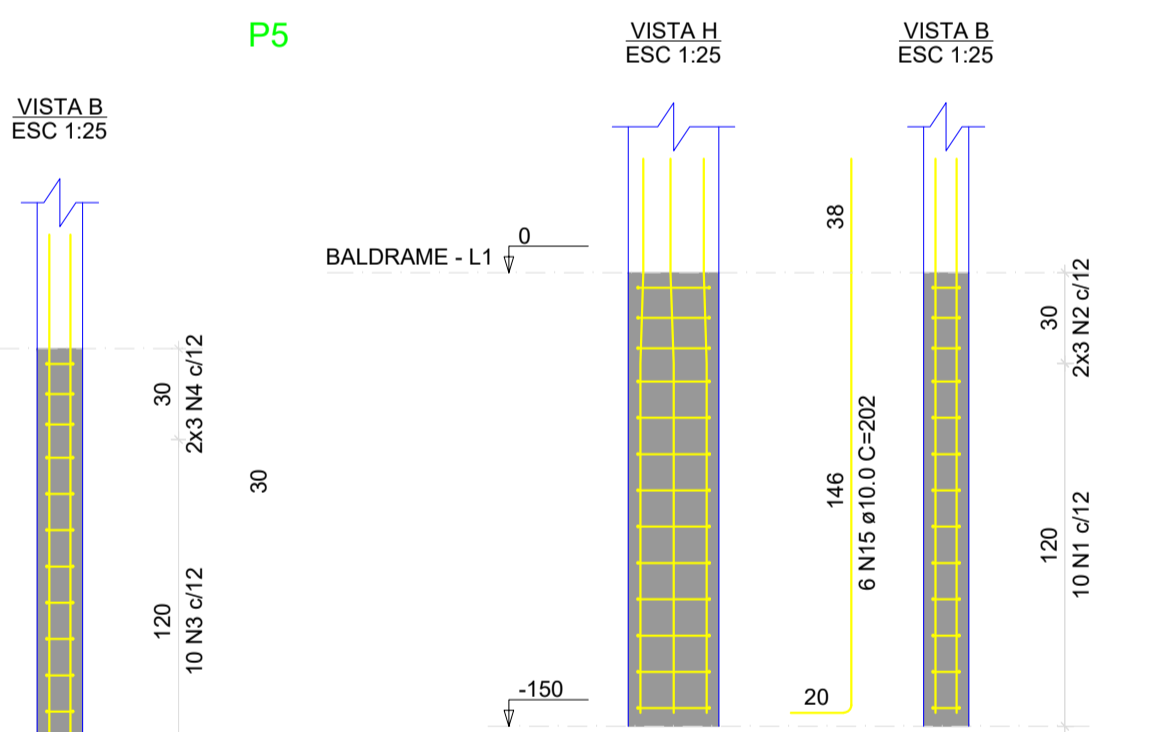

S9
PLANTA
ESC 1:25

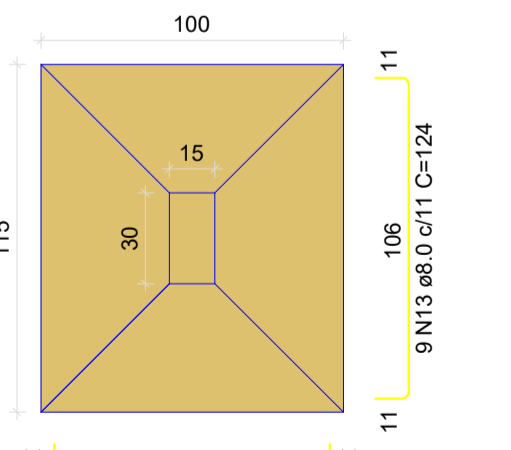

Solo com capacidade de suporte > 1.50 kgf/cm²
Solo compactado sobre a sapata
peso específico > 1600.00 kg/m³

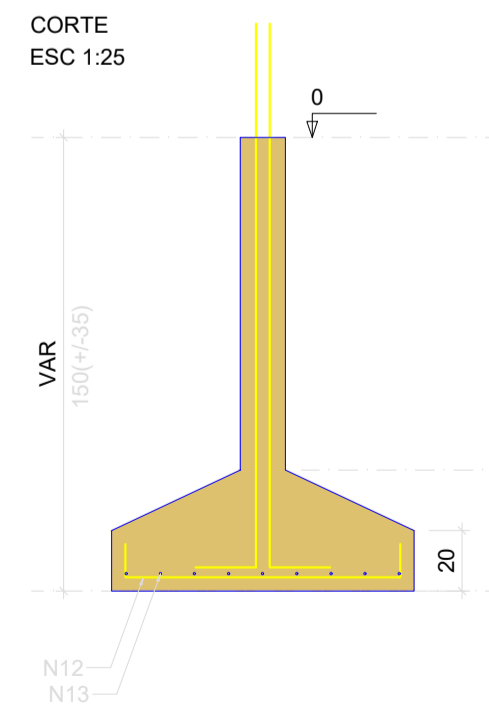

P9

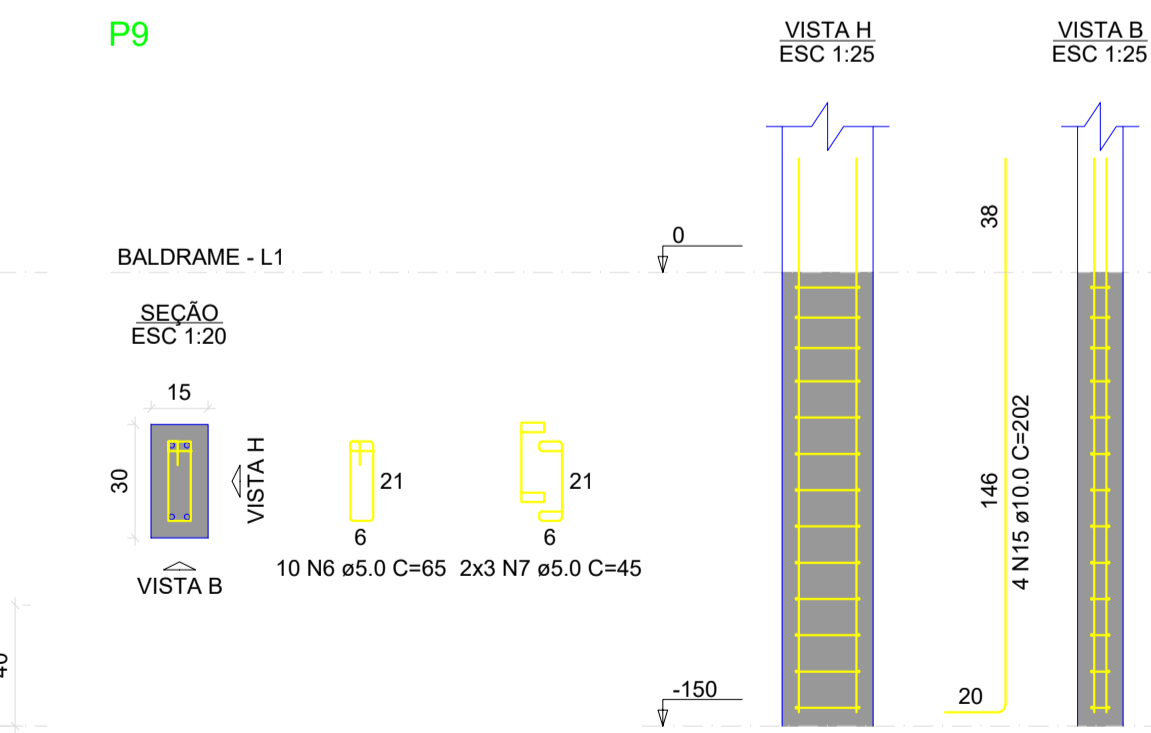

P2

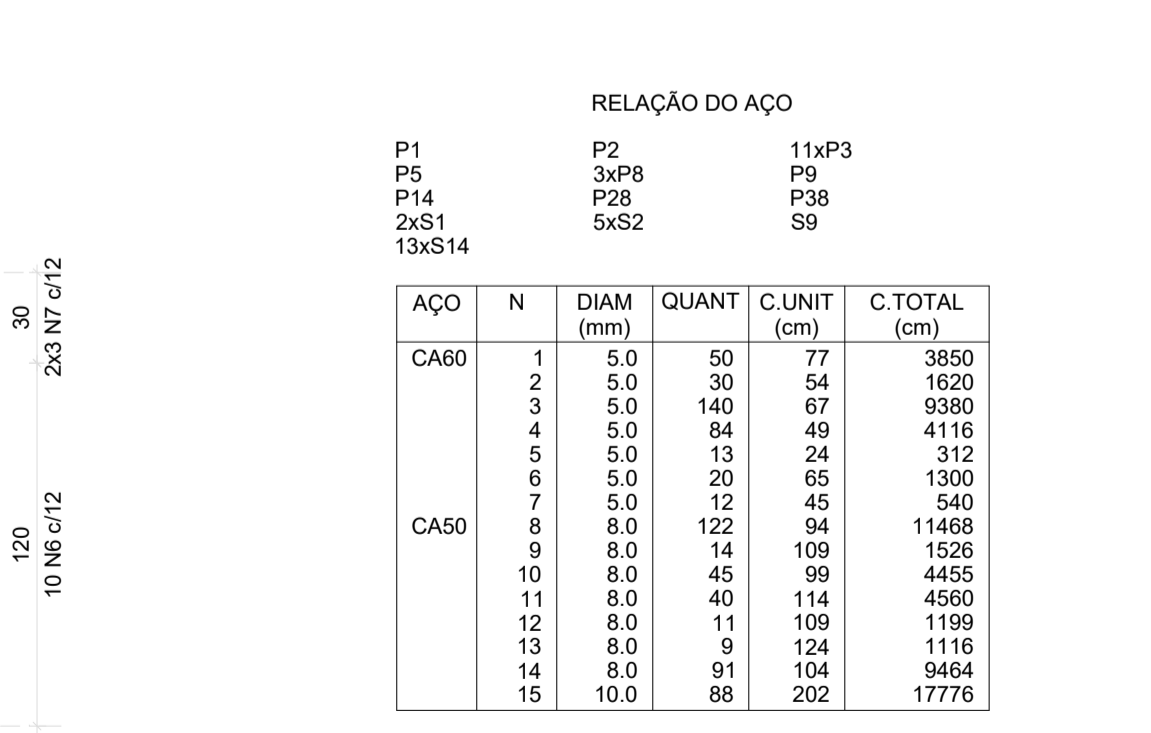

RELAÇÃO DO AÇO

AÇO	N	DIAM (mm)	QUANT	C.UNIT (cm)	C.TOTAL (cm)
CA60	1	5.0	50	77	3850
	2	5.0	30	54	1620
	3	5.0	140	67	9380
	4	5.0	84	49	4116
	5	5.0	13	24	312
	6	5.0	20	65	1300
	7	5.0	12	45	540
	8	8.0	122	94	11488
	9	8.0	14	109	1526
	10	8.0	45	99	4455
	11	8.0	40	114	4560
	12	8.0	11	109	1199
	13	8.0	9	124	1116
	14	8.0	91	104	9464
	15	10.0	88	202	17776

RESUMO DO AÇO

AÇO	DIAM (mm)	C.TOTAL (m)	PESO + 10% (kg)
CA50	8.0	337.9	146.7
CA60	10.0	177.8	120.6
CA60	5.0	211.2	35.8
PESO TOTAL (kg)			
CA50			267.2
CA60			35.8

Volume de concreto (C-25) = 5.50 m³
Área de forma = 36.54 m²

PLANTA DE SITUAÇÃO

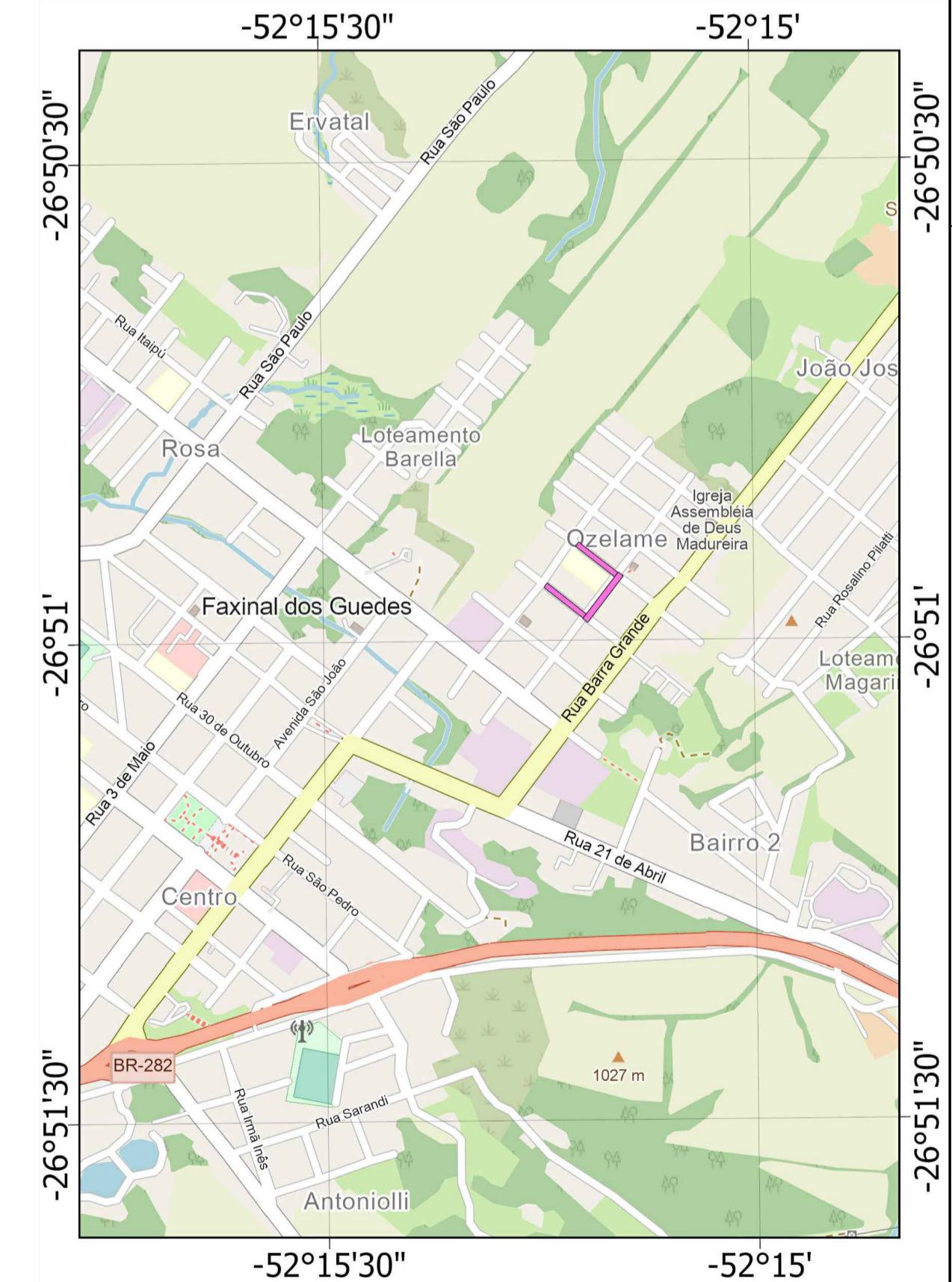

PROJETO ESTRUTURAL

Folha: 6/6

RUA: RUA DOM GIÁCOMO
MUNICÍPIO(S): FAXINAL DOS GUEDES
DATA: 11/2024
ESTADO UF: SC
ESCALA: 1:500

Prop.: PREFEITURA MUNICIPAL DE FAXINAL DOS GUEDES

Resp. Téc.: MICHELE SANTIN ARQUITETA E URBANISTA CAU A 73047-5



FAXINAL DOS GUEDES - SC
GOVERNO MUNICIPAL
Av. Rio Grande do Sul, 458 - Centro
CEP: 89694-000 - Fone: (49) 3436-4300
www.faxinal.sc.gov.br